

INSTALLATION AND USER GUIDE



EspenEV.com

EVC/A48Sx2
LEVEL 2 DUAL HANDLE EV CHARGER



TABLE OF CONTENTS

- 1. IMPORTANT SAFETY INSTRUCTIONS1**
- 2. PRODUCT INFORMATION.....3**
- 3. VERIFY CONTENTS.....5**
- 4. REQUIRED TOOLS7**
- 5. HARDWIRING THE CHARGER8**
- 6. CHOOSING A MOUNTING LOCATION12**
- 7. CMOUNTING THE CHARGER.....13**
- 8. OPERATING THE CHARGER15**
- 9. LED INDICATORS21**
- 10. FCC DECLARATION22**
- 11. WARRANTY AND MAINTENANCE.....23**

WARNING & CAUTION

1. Important Safety Instructions

1.1 Overall Warnings & Cautions

- WARNING:** To avoid fire, injury or death, carefully read and follow the instructions during installation, operation and maintenance.
 - **DO NOT** put fingers into the electric vehicle connector.
 - **DO NOT** use this product if the flexible power cord or EV cable is frayed, insulation-broken, or any other signs of damage.
 - **DO NOT** use this product if the enclosure or the EV connector is broken, cracked, open, or shows any other indication of damage.
 - **DO NOT** remove cover or attempt to open the enclosure because of risk of electric shock.
- WARNING:** This device should be supervised when used around children.
- WARNING:** This device must be grounded.
- WARNING:** To avoid a risk of fire or electric shock, do not use this device with an extension cord.
- WARNING:** The suitability of the use of flexible cord in accordance with CE code, part I, rule 4-012, is to be determined by the local inspection authority.
- WARNING:** To reduce the risk of fire, connect only to a circuit provided branch circuit over-current protection in accordance with the CSA C22.1–15 Canadian Electrical Code, Part 1 (Canada) or NOM-001-SEDE Electrical installations (utility) (Mexico) or ANSI / NFPA 70 National Electrical Code (USA).

Circuit Breaker Options table

Output Amperage (A)		32A*2	40A*2	48A*2
Circuit Breaker Options (A)	Method 1	40A*2	50A*2	60A*2
Circuit Breaker Options (A)	Method 2	80A	100A	120A

WARNING & CAUTION

1.2 Installation Requirements

- WARNING:** Disconnect electrical power prior to installing the charging station.
- WARNING:** Be sure to preview the user manual and ensure local building and electrical codes are reviewed before installing the AC charger.
- WARNING:** The AC charger should be installed by a qualified technician according to the user manual and local safety regulations.
- CAUTION:** Use appropriate protection when connecting to the main power distribution cable.
- CAUTION:** Type B, C or D breaker with the rating current for table should be installed in the upstream AC distribution box.
- CAUTION:** The device shall be mounted at height between 600 mm and 1200 mm from ground.
- CAUTION:** Please keep the charger in a clean area with low humidity. Not recommended to be installed in coastal environments with high humidity or high dust.

1.3 Daily Maintenance

- CAUTION:** Avoid moisture or water in the charger. If there is water or moisture ingress in the charger, it is necessary to immediately power off to avoid immediate danger, and notify the professionals to carry out maintenance before next use.
- CAUTION:** Please use the charger properly. Do not hit or press hard on the enclosure. If it is damaged, please contact a professional technician.
- CAUTION:** Avoid placing the charger near hot objects and at high temperature locations and away from dangerous substances such as flammable gases and corrosive materials.
- CAUTION:** Do not put heavy objects on the charger to avoid danger.

2. Product Introductions



CAUTION: Avoid placing the charger near hot objects and at high temperature locations and away from dangerous substances such as flammable gases and corrosive materials.

2.1 Basic Interface

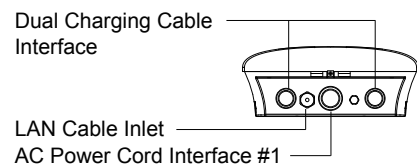
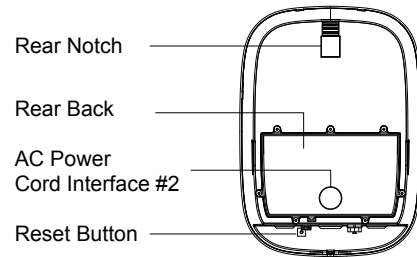
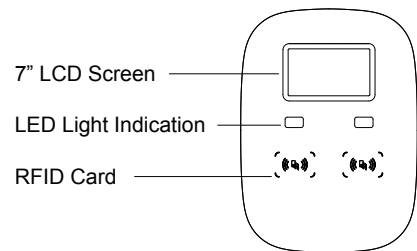

2.2 Basic Dimension

Enclosure

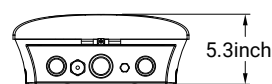
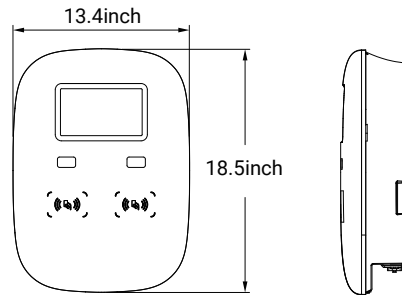

Wall-Mounted Bracket

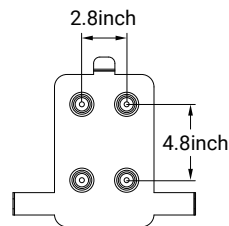

2.3 Specifications

Model Number	EVC/A48Sx2
Rated Input Voltage	208 / 240 VAC
Rated Output Current	32A*2 / 40A*2 / 48A*2
AC Power Frequency	60 Hz
Input Protection	UVP, OVP, RCD, SPD, Ground Fault Protection
Output Protection	OCP, OTP, Control Pilot Fault Protection
Output Interface	SAE J1772 AC Charging Connector
Storage Temperature	-40°F to 158°F
Operation Temperature	-22°F to 122°F
Relative Operation Humidity	95% RH Maximum
Relative Storage Humidity	95% RH Maximum
Network Connection	LAN Version / Wi-Fi Version / 4G version
Internet Function	10M / 100M Base-T
Wi-Fi Function	802.11 b/g/n
3G / 4G Function	GSM / 3G / 4G
Cable Length	Type 3
Installation Type	Wall-Mounted
Altitude	≤ 6561ft
Status Indication	Red, Green, Blue LED

3. Verify Contents

Check the box to ensure you have this installation guide and these parts:

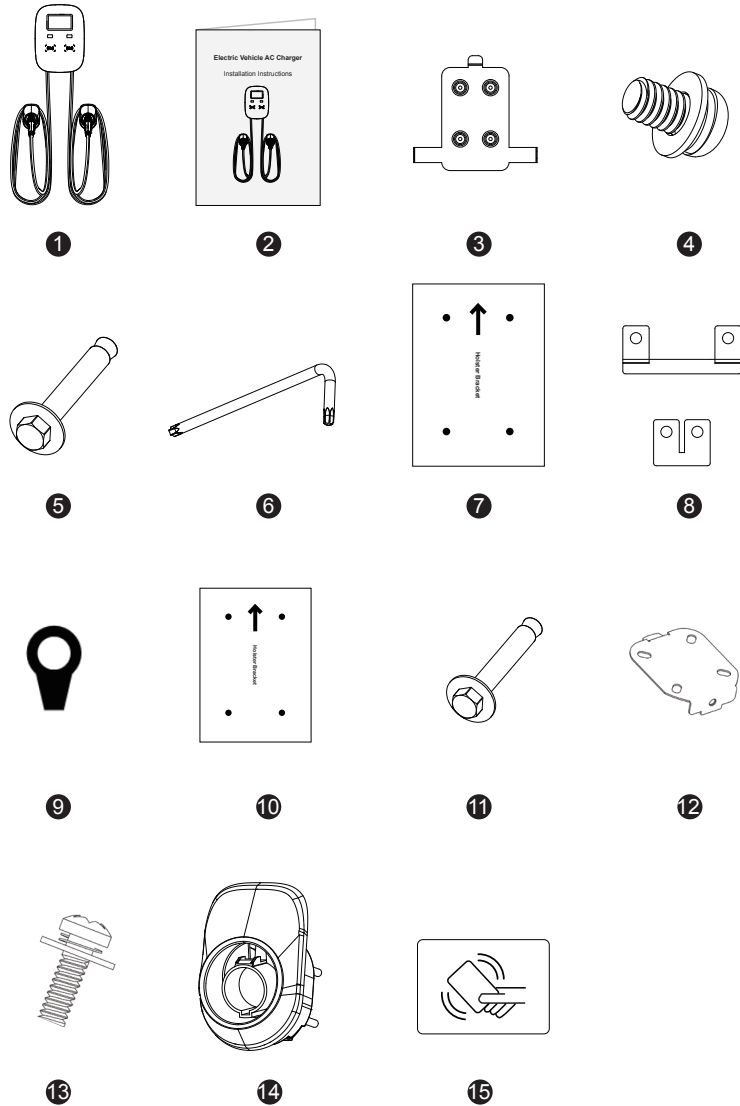

No.	Product Name	Quantity	Description
1	AC Charger	1	Two Charging Cable
2	User Manual	1	Please read carefully before use
3	Wall-Mounted Bracket	1	For mounting the charging station to the wall / structure
4	M5 Anti-Theft Round Head Screws	2	For securing the charging station to the Mounting Bracket
5	M6 Hexagonal Expansion Screws	4	For installing the Mounting Bracket to the wall / structure
6	Allen Wrench	1	For tightening M5 Screws
7	Corrugated Mounting Template	1	For easy drilling of 4 screws holes for wall-mounted bracket
8	Shorting Terminal	1	Using in Wiring Method 2
9	Tinned Copper OT Terminal	6	For electrical wiring
10	Corrugated Mounting Template (Optional)	2	For easy drilling of 4 screws holes for holster bracket
11	Holster Bracket Screws (Optional)	8	For mounting the Holster Bracket to the wall / structure
12	Holster Bracket (Optional)	2	For fixing the Plug Holster
13	Plug Holster Screws (Optional)	2	For mounting the Plug Holster to the Holster Bracket
14	Plug Holster (Optional)	2	For allowing the plugs to be neatly and safely stored when not in use
15	RFID Card (Optional)	2	Control the charger start / stop

4. Gather Tools

Tools required before installing the Wall-Mounted charger, gather the following tools:

1. Wire stripper
2. Adjustable Wrench
3. Voltmeter or digital multi-meter (for measuring AC voltage at the installation site)
4. OT Terminal crimping pliers
5. Level
6. Pencil or marker
7. Drill
8. Phillips screwdriver

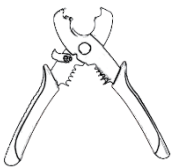

1



2

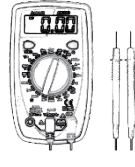

3



4

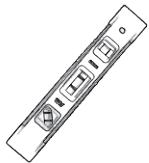

5

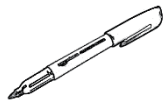

6



7

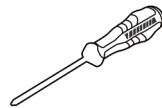

8

Note: The above tools are very important, please gather them all.

5. Wiring The Circuit



WARNING: This device must be grounded. Disconnect electrical power prior to installing the charging station.



WARNING: Improper connection of the equipment-grounding conductor would result in a risk of electric shock. Check with a qualified electrician or serviceman if you are not sure whether the product is properly grounded. Do not modify the plug provided with the product – if it doesn't fit the outlet, have a proper outlet installed by a qualified electrician.



CAUTION: Use appropriate protection when connecting to the main power distribution cable.

For safe use of electricity, please set circuit breaker protection in the input part of EV Charger The wiring is not complicated, just need to follow the instructions below:

Wiring preparation

Remove the 7 screws of the rear back of the EV charger, and remove the rear back by pressing the groove where the arrow is shown in the figure. We provide two wiring methods.

Method 1: Two AC Power Cord and two Charging Cable

Method 2: One AC Power Cord and two Charging Cable

(Using shorting terminals to connect AC1_L1 and AC2_L1, connect AC1_L2 and AC2_L2) Please note that AC Power Cord Interface #1 is commonly used and the #2 is a spare.

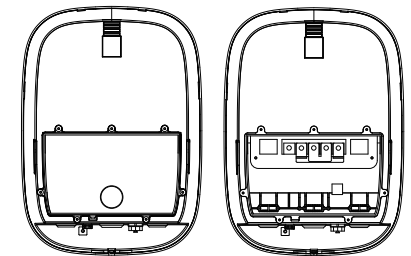

Method 1: Two Phase 120VAC Wiring (2 Cable)

Circuit Breaker Options table			
Output Amperage (A)	32A*2	40A*2	48A*2
Circuit Breaker Options (A)	40A*2	50A*2	60A*2

STEP 1

Press the wires of AC power cord onto the OT terminals in the accessory kit

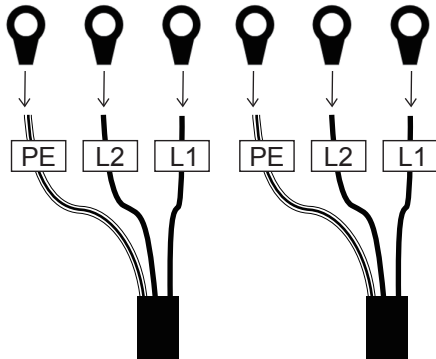

STEP 2

Pass the two AC power cords through the AC Power Cord Interface #1

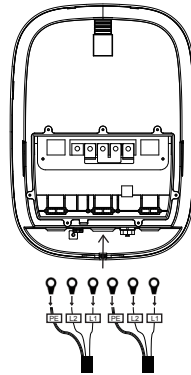

STEP 3

Connect the five terminals according to the following wiring methods image, and connect the two PE together.

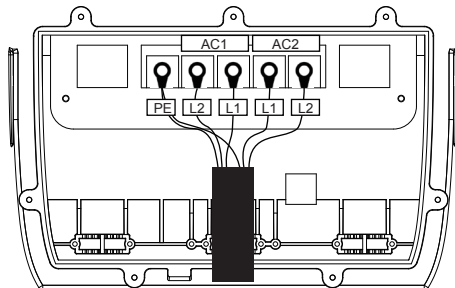

Method 2: Single Phase 240VAC Wiring (1 Cable)

Circuit Breaker Options table			
Output Amperage (A)	32A*2	40A*2	48A*2
Circuit Breaker Options (A)	80A	100A	120A

STEP 1

Press the wires of AC power cord onto the OT terminals in the accessory kit

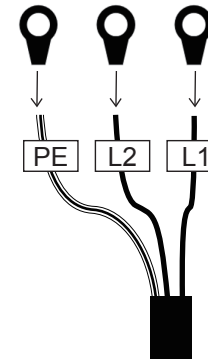

STEP 2

Pass the AC power cords through the AC Power Cord Interface #1

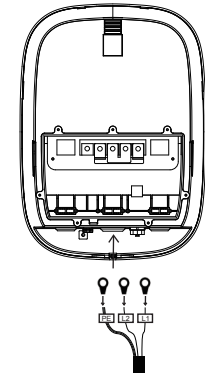

STEP 3

Take out the shorting terminals in the accessory package. Connect AC1_L1 and AC2_L1, and connect AC1_L2 and AC2_L2 according to the following wiring methods image.

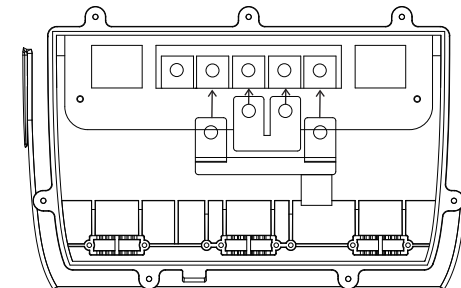

STEP 4

Connect to 3 terminals according to the following wiring methods

image: L1 is connected to L1, L2 is connected to L2, and PE is connected to PE.

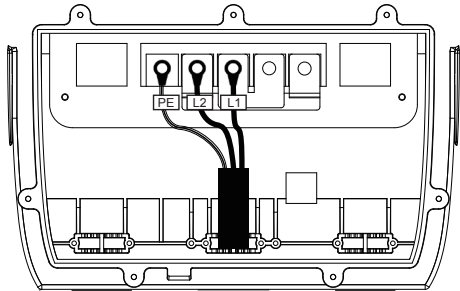

Wiring complete

After the wiring is completed, cover the rear back and tighten the 7 screws.

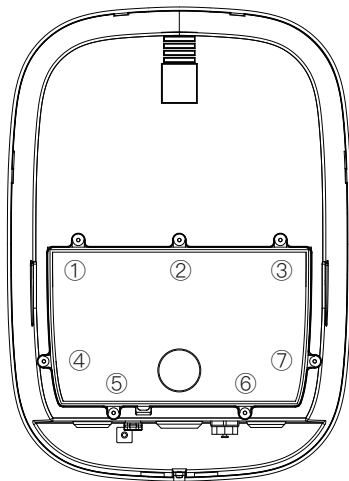

6. Plan The Mounting

WARNING: In areas with frequent thunderstorms, add surge protection at the service panel



for all circuits. Ensure all power and ground connections, especially those at the breaker and bus bar, are clean and tight.



CAUTION: Not recommended to be installed in coastal environments with high humidity or high dust.

STEP 1

Select the appropriate mounting location with electrical capacity:

I. Ensure the owner has chosen a mounting location that allows the charging cable to reach the car's charging port while still providing slack.

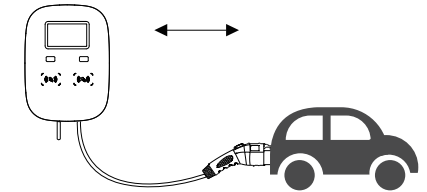

II. The device must be anchored into mounting such as 3.14" x 5.11" stud or a solid wall.

III. The device shall be mounted at height between 2 feet and 4 feet from ground.

STEP 2 (Charging Handle Holder is optional)

Drill 12 Screw Holes with a diameter of 0.33" and a depth of 2.2" by using our mounting template. Please drill screw holes in the direction of the template arrow.

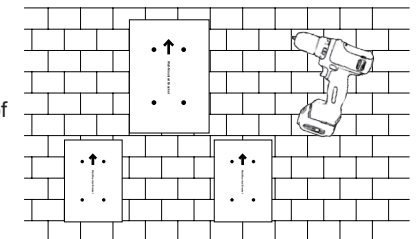

7. Mount the Charging Station

STEP 1

Use 4 sets Hexagonal Expansion Screws to secure the wall-mounted bracket on the wall. Then level the brackets.

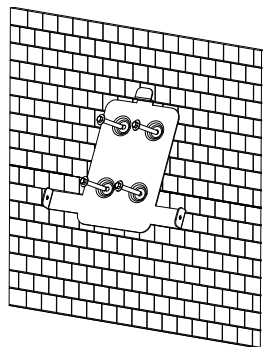

STEP 2

Align the rear notch of charger with the wall-mounted bracket and fit the screw holes of the right and left side.

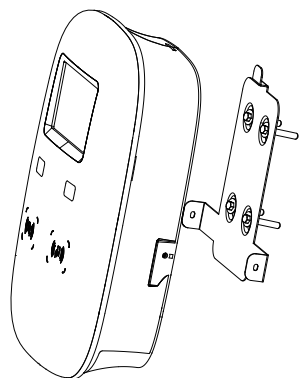

STEP 3

Tighten two M5 anti-theft screws to complete the installation.

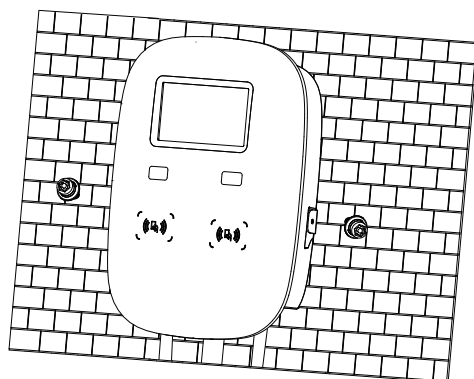

STEP 4 (Holster is optional)

Install the holder as shown in the figure (Same mounting as the charger)

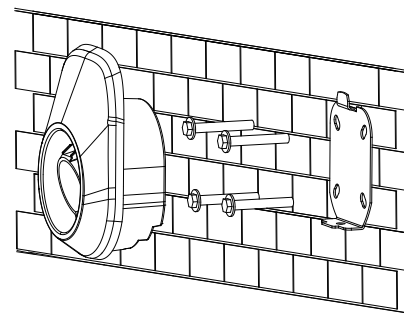

STEP 5 (Holder is optional)

Tighten one M5 anti-theft screws to complete the installation.

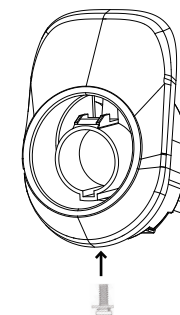

Overall outlook picture after installation (Holder is optional)

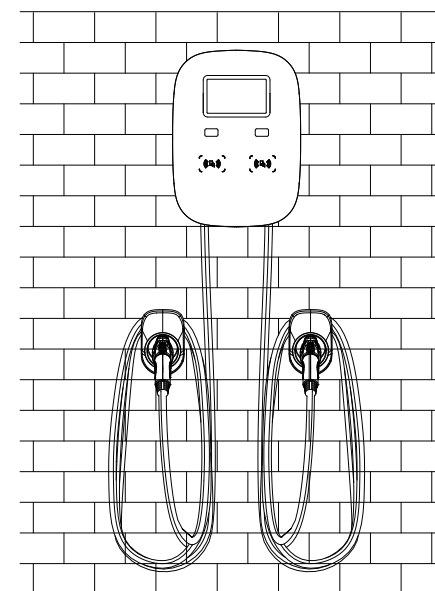

8. Operate Your Device



WARNING: This device should be supervised when used around children.



CAUTION: Please use the charger properly. Do not hit or press hard on the enclosure. If the case is damaged, please contact a professional technician.



CAUTION: Do not put heavy objects on the charger to avoid danger.

8.1 Operating Steps with Plug and Charge

STEP 1

Standby Mode:

Standby Mode: After being powered on, the lights will be all on, blue light (READY), green light (CHARGE) and red light (FAULT). Then the blue light (READY) is constantly on in standby mode. (e.g.AC1)

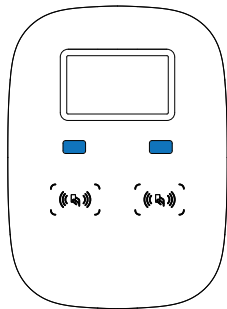

STEP 2

Plug the Charging Connector:

Please plug the charging connector into the vehicle charging inlet.

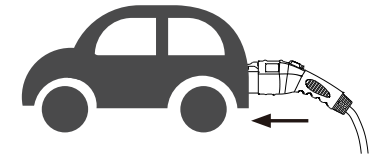

STEP 3

Charging:

The green light (CHARGE) turns to flash automatically, charging is in process. (e.g.AC1)

- If the red light (FAULT) is on, plug the vehicle connector again.
- If red light is still on, please refer to "Error and Warning Messages".

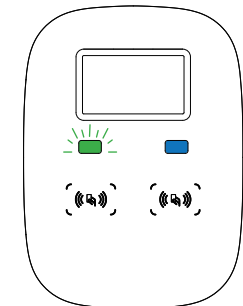

STEP 4

Charging finished:

When the charging is finished, the green light (CHARGE) is constantly on, pull out the charging connector.

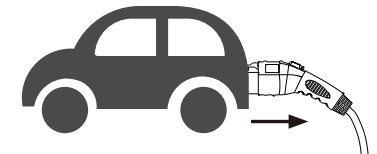

8.2 Operating Steps with RFID (Optional)



CAUTION: Please keep your RFID card properly to avoid unnecessary loss.

STEP 1

Standby Mode:

After power-on, blue light (READY), green light (CHARGE) and red light (FAULT) all on. The blue light (READY) is constantly on when in standby mode. (e.g.AC1)

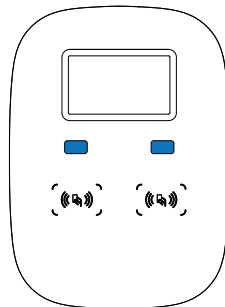

STEP 2

Ready to charge:

Please plug the charging connector into the vehicle charging inlet. When the green light (CHARGE) is constantly on, the user can swipe the RFID Card. (e.g.AC1)

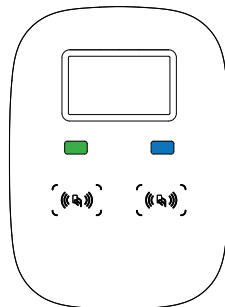
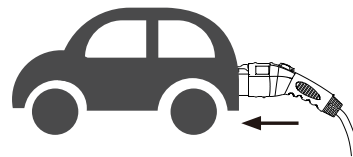

Swipe the RFID Card:

Swipe the RFID card first and plug in the charging connector within 120 seconds, otherwise you need to swipe the RFID card again. (e.g.AC1)

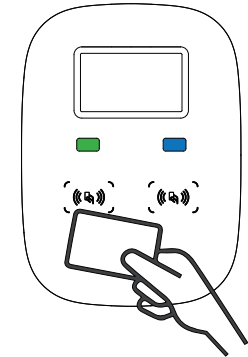

STEP 4

Charging:

The green light (CHARGE) turns to flash automatically, charging is in process.

- If the red light (FAULT) is on, plug in the charging connector again.
- If red light is still on, please refer to "Error and Warning Messages".

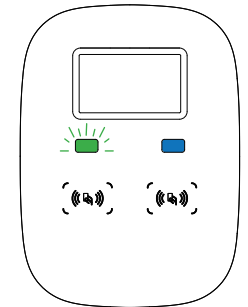

STEP 5



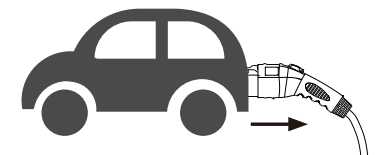
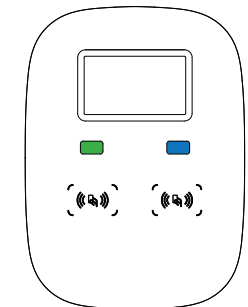

Charging finished:

When the charging is finished or swipe your RFID card, the green light (CHARGE) is constantly on. Please press the button on connector and pull out the charging connector. (e.g.AC1)



9. Light Codes

9.1 After Start UP (e.g.AC1)

Standby, waiting to plug in	Waiting to charge, communicating with vehicle	Charging in progress	Finished charging	Fault
				
Solid Blue	Solid Green	Green Blinking	Solid Green	Solid Red

9.2 Status Indicator

Fault Status	Red	Remark
Voltmeter fault	1 flash followed by 3 sec pauses	Auto Recover
Control pilot fault	2 flashes followed by 3 sec pauses	Auto Recover (Pull out the charging connector)
Input UVP	3 flashes followed by 3 sec pauses	Auto Recover
Input OVP	4 flashes followed by 3 sec pauses	Auto Recover
OTP	5 flashes followed by 3 sec pauses	Auto Recover
OCP	6 flashes followed by 3 sec pauses	Auto Recover (Pull out the charging connector)
Ground fault	7 flashes followed by 3 sec pauses	Auto Recover (Pull out the charging connector)
Relay fault	8 flashes followed by 3 sec pauses	Auto Recover (Pull out the charging connector)
RCD abnormal	9 flashes followed by 3 sec pauses	Auto Recover (Pull out the charging connector)
RCD self-test fault	10 flashes followed by 3 sec pauses	Reboot Recover

10. FCC Declaration

This device complies with part 15 of the FCC Rules.

Operation is subject to the following two conditions:

This device may not cause harmful interference, and this device must accept any interference received, including interference that may cause undesired operation.

Caution: Changes or modifications to this unit not expressly approved by the party responsible for compliance could void the user's authority to operate the equipment.

Note: This equipment has been tested and found to comply with the limits for a Class A digital device, pursuant to part 15 of the FCC Rules. These limits are designed to provide reasonable protection against harmful interference when the equipment is operated in a commercial environment. This equipment generates, uses, and can radiate radio frequency energy and, if not installed and used in accordance with the instruction manual, may cause harmful interference to radio communications. Operation of this equipment in a residential area is likely to cause harmful interference in which case the user will be required to correct the interference at his own expense.

WiFi module: Containing FCC ID:2AC7Z-ESPWROOM32D

LTE module: Containing FCC ID: XMR202008EC25AFXD

To satisfy FCC RF exposure requirements, a separation distance of 20cm or more should be maintained between the antenna of this device and persons during device operation. To ensure compliance, operations at closer than this distance is not recommended.

11. Warranty and Maintenance

- The standard limited warranty period for this charger is two years.
- During the warranty period for any malfunction under normal use according to the User Manual (to be determined by Espen Qualified maintenance technicians), any component failures will be replaced free of charge. Except for the following situations, the charger shall be subject to the above warranty terms:
 1. The warranty certificate cannot be provided or the contents of the warranty certificate are modified or inconsistent with the label indication of the repaired product.
 2. Those who are unable to provide valid proof of purchase.
 3. Those who exceed the manufacturer's specified warranty period.
 4. Those who damage the product due to not following the product service instruction for use, maintenance and storage.
 5. Damage or malfunction caused by an external object.
 6. Unauthorized repair, disassembly or modification.
 7. Damage caused by force majeure (such as lightning, excessive voltage, earthquake, fire, flood, etc.).
 8. Malfunction and damage caused by other unavoidable external factors. Malfunction and damage caused by improper use of equipment, such as water or other liquids entering into the equipment.
 9. Malfunction and damage caused by the grid power supply and voltage which is not specified for use with the charger equipment.

The above guarantees shall be made solely, and no other express or implied warranties shall be made (including the implied warranties of merchant ability, particular and applicable reason- ableness and adaptability, etc.) whether in the contract, civil negligence, or other aspects, Espen shall not be responsible for any special, incidental or consequential damages.

MAINTENANCE: Any Maintenance or repair should be performed by a qualified electrician after consultation with Espen on the nature of the malfunction.